

# 180 W 969 nm and 976 nm Locked Fiber- Coupled Diode Pump Laser Module

ST Series: ST2-L



ST2-L delivers 180 W of power within 0.15 numerical aperture of 135  $\mu\text{m}$  core fiber. The pump operates at 969 nm or 976 nm in a narrow wavelength range using internal locking techniques ideal for pumping Yb:YAG material and fiber laser. It uses a new generation of high-power proprietary chip optimized for reliability at high power.

The multimode pump module offers high power, small size, and simplified thermal management. The diode operates as distributed heat sources, allowing air- or water-cooled architectures with predictable high reliability.

The ST2-L Series is a unique solution for the fiber-coupled pump laser market that requires wavelength accuracy. It offers powerful technical attributes in a cost-effective package.

**Key Features**

- 180 W output power into 0.15 numerical aperture (NA) of 135  $\mu\text{m}$  core
- 969 nm and 976 nm wavelengths, locked in a narrow wavelength range
- High reliability
- 0.22 NA fiber
- Isolated electrical contacts

**Applications**

- Pumping of fiber laser and Yb:YAG material

**Dimensions Diagram**

(Specifications in mm unless otherwise noted.)

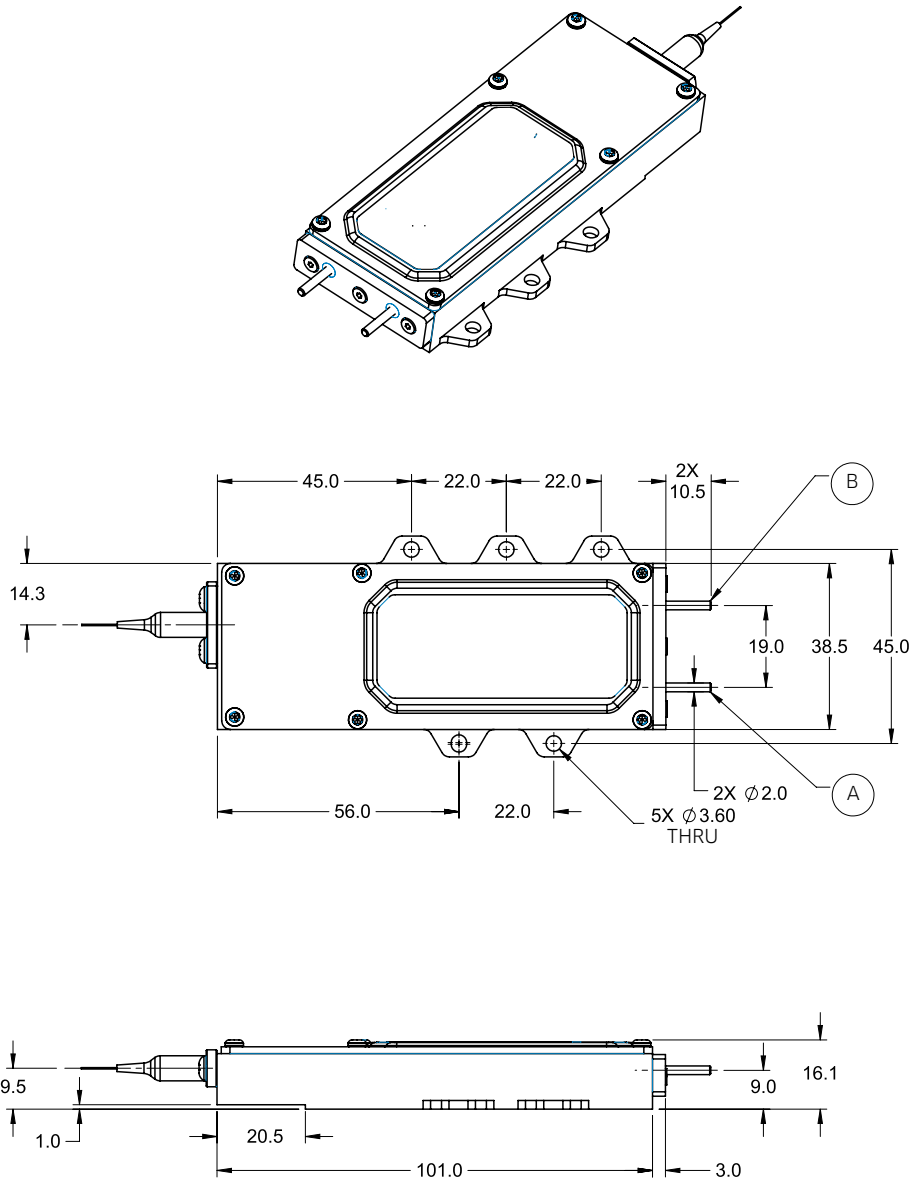

**Pinout**

| Pin | Description       |
|-----|-------------------|
| A   | Laser cathode (-) |
| B   | Laser anode (+)   |

**Specifications<sup>1</sup>**

| Parameter   | Symbol                   | Minimum              | Typical           | Maximum             |
|---|--------------------------|----------------------|-------------------|---------------------|
| <b>Laser Characteristics at 180 W Output Power</b>                                  |                          |                      |                   |                     |
| Maximum operating current set point (BOL)   | $I_{op,max}$             | —                    | 15 A              | 17 A                |
| <b>Laser Characteristics at 180W output power and 35°C maximum case temperature</b> |                          |                      |                   |                     |
| Maximum operating voltage   | $V_{op,max}$             | 23.0                 | 24.4              | 25.4 V              |
| Electrical-to-optical conversion efficiency   | PCE                      | 36%                  | 44%               | —                   |
| Wavelength range (90% of power within band)   | $\lambda$                | 968.5 nm<br>974.5 nm | —                 | 970 nm<br>977.5 nm  |
| Spectral width (FWHM)   | —                        | —                    | —                 | 1 nm                |
| Wavelength shift with temperature   | $\Delta\lambda/\Delta T$ | —                    | 0.01 nm/°C        | —                   |
| Back reflection isolation to diode (1030-1064 nm)                                   | —                        | 30 dB                | —                 | —                   |
| Light within 0.15 NA  | —                        | 95%                  | —                 | —                   |
| <b>Fiber Characteristics</b>  |                          |                      |                   |                     |
| Fiber core diameter   | $d_c$                    | 133.5 $\mu\text{m}$  | 135 $\mu\text{m}$ | 136.5 $\mu\text{m}$ |
| Fiber numerical aperture  | NA                       | 0.215                | 0.22              | 0.235               |
| Fiber cladding diameter   | $d_{cl}$                 | 153 $\mu\text{m}$    | 155 $\mu\text{m}$ | 157 $\mu\text{m}$   |
| Fiber buffer diameter <sup>2</sup>  | $d_b$                    | 300 $\mu\text{m}$    | 320 $\mu\text{m}$ | 340 $\mu\text{m}$   |
| Total fiber length  | $L_f$                    | 1.2 m                | 1.5 m             | —                   |
| Fiber bend radius   | —                        | 35 mm                | —                 | —                   |
| Fiber axial pull force, 15 s  | —                        | —                    | —                 | 5 N                 |
| Fiber side pull force, 15 s   | —                        | —                    | —                 | 2.5 N               |

1. All electrical and optical performance data referenced at 35°C case temperature and at 180 W output power unless noted.

2. Low index coating.

Note: Cold plate typically needs to be chilled to 25°C-30°C to maintain 35°C pump case temperature.

**Environmental Requirements**

| Parameter  | Minimum | Maximum | Notes  |
|--|---------|---------|--|
| Case operating temperature (base of laser housing)     | 26°C    | 36°C    | Mounting feet can be used to approximate base temperature. |
| Storage and transportation temperature (non-operating) | -40°C   | 85°C    | Non-condensing under operation and storage.                |
| Electrostatic discharge (ESD)                          | —       | 500 V   | HBM  |
| Maximum voltage between any pin and package            | —       | 85 V    |  |
| RoHS   | —       | —       | Compliant  |

### Operating Considerations

Operating the diode laser outside at maximum ratings may cause device failure or a safety hazard. Power supplies used with the component must be employed so that the maximum peak optical power cannot be exceeded. CW diode lasers may be damaged by excessive drive current or switching transients. When power supplies are used, the diode laser should be connected with the main power on and the output voltage at zero. The current should be increased slowly while the diode laser output power and the drive current are monitored.

Device degradation accelerates with increased temperature, and thus the case temperature should be minimized and the unit operated in a non-condensing atmosphere.

A proper heatsink for the diode laser on a thermal radiator will greatly enhance laser life. Refer to the product application note for more information regarding heat sinking and mounting the product.

### Electrostatic Discharge (ESD) Protection

ESD is the primary cause of unexpected diode-laser failure. Take extreme precaution to prevent ESD. Use wrist straps, grounded work surfaces, and rigorous antistatic techniques when handling diode lasers.

### Laser Safety



Note: This component requires provisions of drive and control electronics before emitting laser radiation.

Laser classification depends on the system control circuit and laser safety features provided.

This diode-pumped laser module is not 21CFR 1040.10 or IEC 60825-1:2014 certified. It is a component intended for system integration. Compliance with 21CFR 1040.10 and/or IEC 60825-1:2014 will need to be determined at the system level.

Lumentum has registered this laser with the FDA/CDRH as an OEM component. Please contact Lumentum for an FDA/CDRH accession number for this laser component.

### Serial Number Identification Label



### Ordering Information

For more information on this or other products and their availability, please contact your local Lumentum account manager or Lumentum directly at [customer.service@lumentum.com](mailto:customer.service@lumentum.com).

| Description   | Part Number |
|---|-------------|
| 180 W fiber-coupled diode pump laser module, 969 nm, without loose tubing | 22236820    |
| 180 W fiber-coupled diode pump laser module, 976 nm, without loose tubing | 22236818    |



North America  
Toll Free: 844 810 LITE (5483)

Outside North America  
Toll Free: 800 000 LITE (5483)

China  
Toll Free: 400 120 LITE (5483)

© 2025 Lumentum Operations LLC  
Product specifications and descriptions in this document are subject to change without notice.