

110 W 885 nm and 888 nm Locked Fiber- Coupled Diode Pump Laser Module

ST Series: ST2-L



ST2-L delivers 110 W of power within 0.15 numerical aperture of 135 μm core fiber. The pump operates at 885 nm and 888nm in a narrow wavelength range using internal locking techniques ideal for pumping neodymium-based laser. It uses a new generation of high-power proprietary chip optimized for reliability at high power.

The multimode pump module offers high power, small size, and simplified thermal management. The diode operates as distributed heat sources, allowing air- or water-cooled architectures with predictable high reliability.

The ST2-L Series is a unique solution for the fiber-coupled pump- laser market that requires wavelength accuracy. It offers powerful technical attributes in a cost-effective package.

Key Features

- 110 W output power into 0.15 numerical aperture (NA) of 135 μm core
- 885 nm and 888 nm wavelengths, locked in a narrow wavelength range
- High reliability
- 0.22 NA fiber
- Isolated electrical contacts

Applications

- Pumping of neodymium-based laser with YAG or vanadate co-doping

Dimensions Diagram

(Specifications in mm unless otherwise noted.)

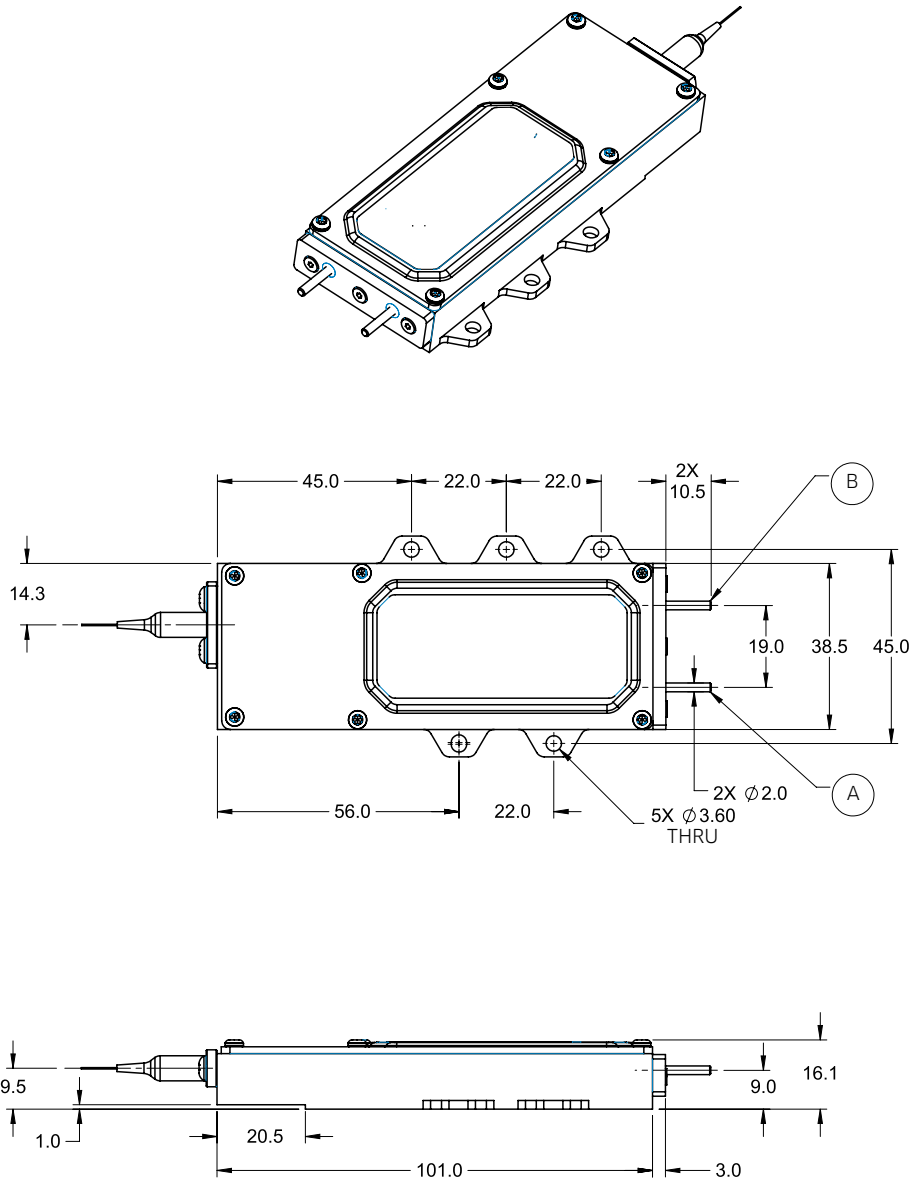

Pinout

Pin	Description
A	Laser cathode (-)
B	Laser anode (+)

Specifications¹

Parameter	Symbol	Minimum	Typical	Maximum
Laser Characteristics at 110 W Output Power				
Maximum operating current set point (BOL)	$I_{op,max}$	—	—	12.6 A
Laser Characteristics at 110W output power and 35°C maximum case temperature				
Maximum operating voltage	$V_{op,max}$	21.0	22.8	23.8 V
Electrical-to-optical conversion efficiency	PCE	38%	44%	
Wavelength range (90% of power within band)	λ	883.6 nm 886.8 nm	—	886.4 nm 889.1 nm
Spectral width (FWHM)				1 nm
Wavelength shift with temperature	$\Delta\lambda/\Delta T$		0.01 nm/°C	
Back reflection isolation to diode (1030-1064 nm)	—	30 dB	—	—
Light within 0.15 NA		95%		—
Fiber Characteristics				
Fiber core diameter	d_c	133.5 μm	135 μm	136.5 μm
Fiber numerical aperture	NA	0.215	0.22	0.235
Fiber cladding diameter	d_{cl}	153 μm	155 μm	157 μm
Fiber buffer diameter ²	d_B	300 μm	320 μm	340 μm
Total fiber length	Lf	1.2 m		2.0 m
Fiber bend radius		35 mm		
Fiber axial pull force, 15 s				5 N
Fiber side pull force, 15 s				2.5 N

1. All electrical and optical performance data referenced at 35°C case temperature and at 110W output power unless noted.

2. Low index coating.

Note: Cold plate typically needs to be chilled to 25°C–30°C to maintain 35°C pump case temperature.

Environmental Requirements

Parameter	Minimum	Maximum	Notes
Case operating temperature (base of laser housing)	25°C	35°C	Mounting feet can be used to approximate base temperature.
Storage and transportation temperature (non-operating)	-40°C	85°C	Non-condensing under operation and storage.
Electrostatic discharge (ESD)		500 V	HBM
Maximum voltage between any pin and package		85 V	
RoHS			Compliant

Operating Considerations

Operating the diode laser outside its maximum ratings may cause device failure or a safety hazard. Power supplies used with the component must be employed so that the maximum peak optical power cannot be exceeded. CW diode lasers may be damaged by excessive drive current or switching transients. When power supplies are used, the diode laser should be connected with the main power on and the output voltage at zero. The current should be increased slowly while the diode laser output power and the drive current are monitored.

Device degradation accelerates with increased temperature, and thus the case temperature should be minimized and the unit operated in a non-condensing atmosphere.

A proper heatsink for the diode laser on a thermal radiator will greatly enhance laser life. Refer to the product application note for more information regarding heat sinking and mounting the product.

Electrostatic Discharge (ESD) Protection

ESD is the primary cause of unexpected diode-laser failure. Take extreme precaution to prevent ESD. Use wrist straps, grounded work surfaces, and rigorous antistatic techniques when handling diode lasers.

Laser Safety



Note: This component requires provisions of drive and control electronics before emitting laser radiation.

Laser classification depends on the system control circuit and laser safety features provided.

This diode-pumped laser module is not 21CFR 1040.10 or IEC 60825-1:2014 certified. It is a component intended for system integration. Compliance with 21CFR 1040.10 and/or IEC 60825-1:2014 will need to be determined at the system level.

Lumentum has registered this laser with the FDA/CDRH as an OEM component. Please contact Lumentum for an FDA/CDRH accession number for this laser component.

Serial Number Identification Label



Ordering Information

For more information on this or other products and their availability, please contact your local Lumentum account manager or Lumentum directly at customer.service@lumentum.com.

Description	Part Number
110 W fiber-coupled diode pump laser module, 888 nm, without loose tubing	22181130
110 W fiber-coupled diode pump laser module, 885 nm, without loose tubing	22181129



North America
Toll Free: 844 810 LITE (5483)

Outside North America
Toll Free: 800 000 LITE (5483)

China
Toll Free: 400 120 LITE (5483)

© 2025 Lumentum Operations LLC
Product specifications and descriptions in this document are subject to change without notice.